

WALL DIAGONAL CORNER CABINETS

1. After inserting splines in FRONT FRAME, lay FRONT face down on a clean, smooth surface.
2. Insert TOP and BOTTOM into the splines in the rails (as shown).
Make sure the rabbet is toward the inside of the cabinet.

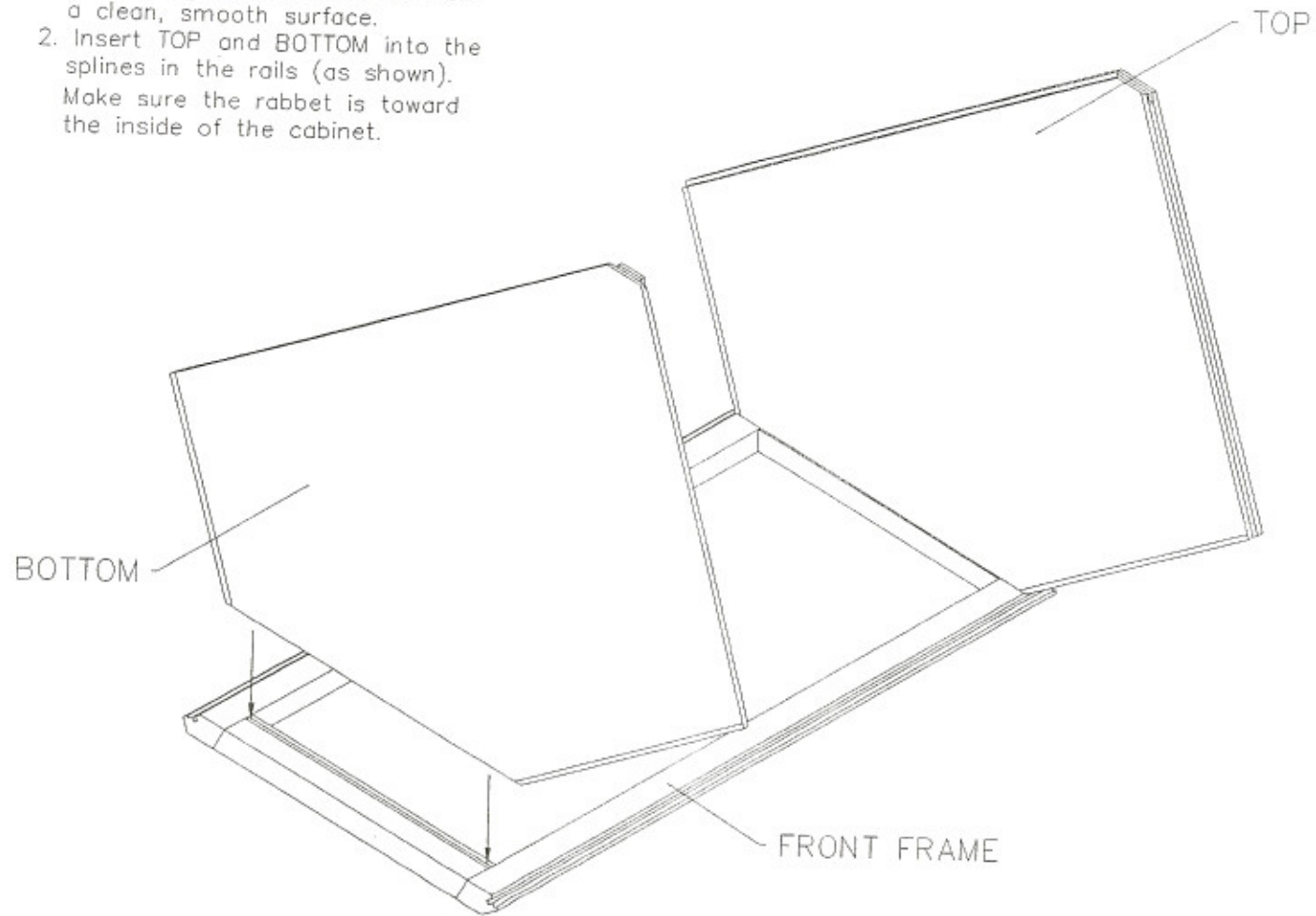

WALL DIAGONAL CORNER CABINETS (cont.)

3. Using the male dovetails on the TOP & BOTTOM, slide the cabinet SIDES into place (as shown). Be sure the grooved edge is inserted first to accept the splines in the FRONT FRAME.
4. Using the rabbets in the TOP & BOTTOM, slide the cabinet BACK towards the SIDE until it is seated in the cabinet SIDE plough.

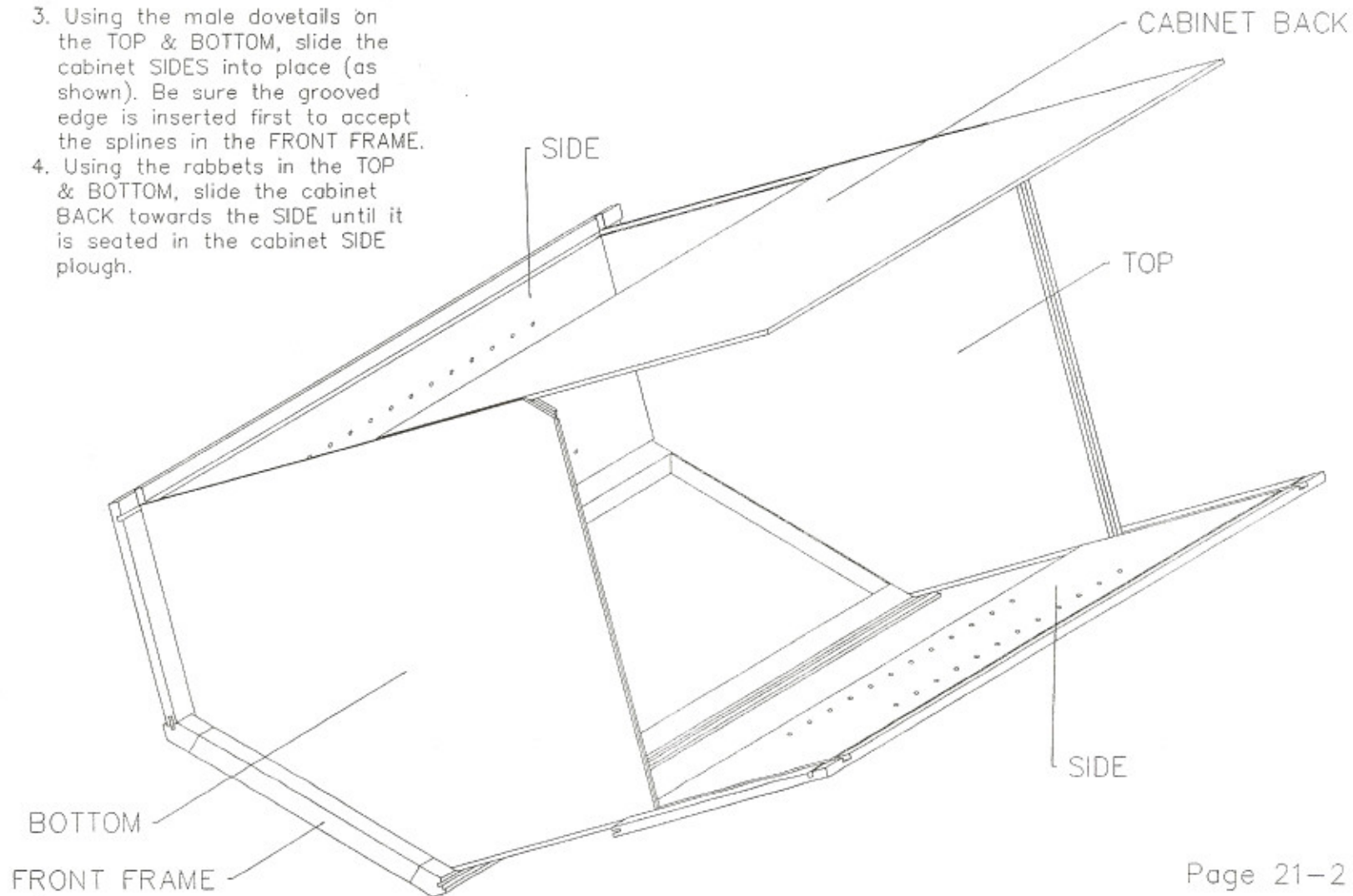

WALL DIAGONAL CORNER CABINETS (cont.)

5. Slide the the other cabinet
BACK into place.

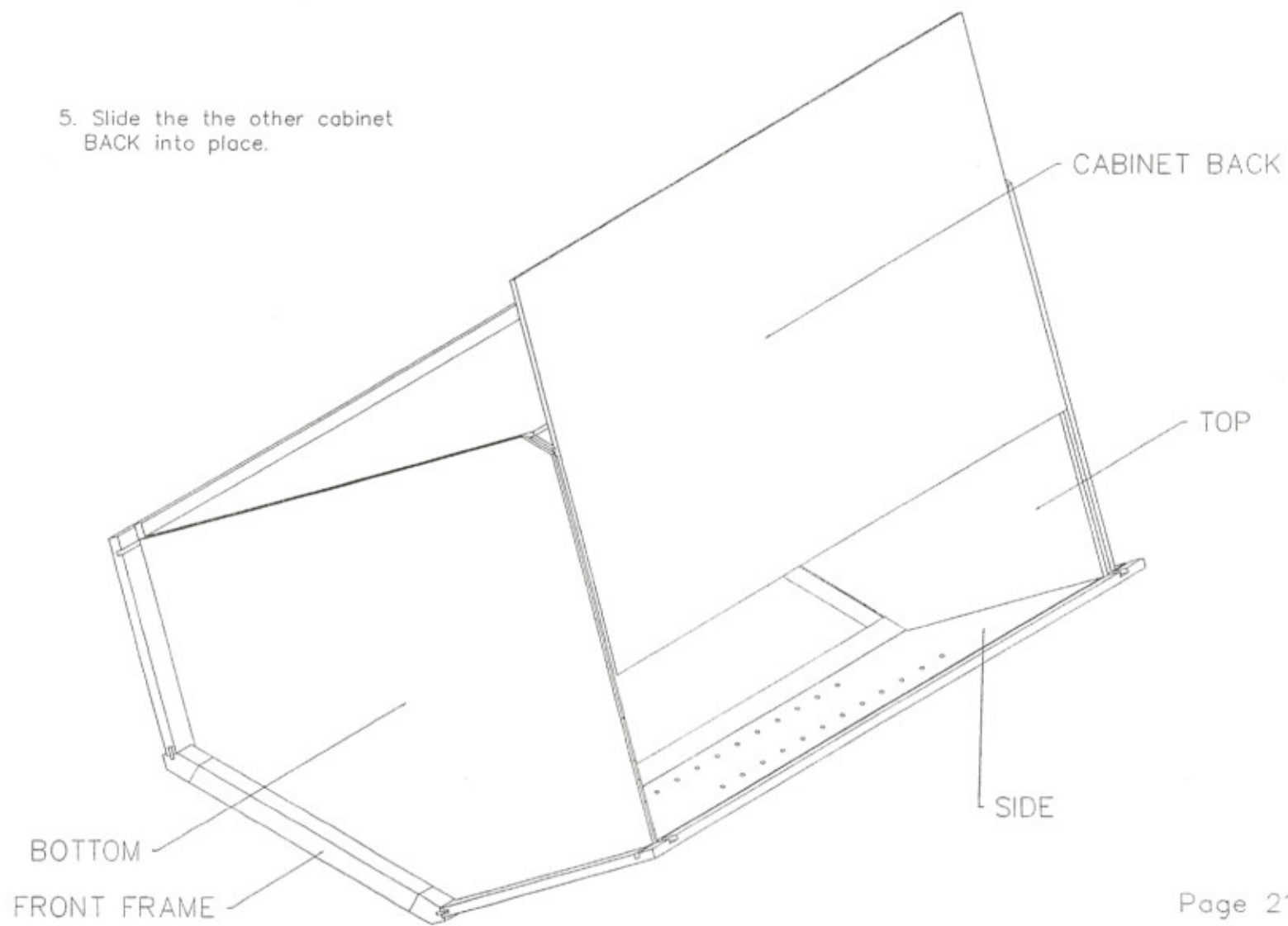

WALL DIAGONAL CORNER CABINETS (cont.)

6. Glue a $7/8$ " spline in the groove of the BACK CORNER PIECE where the TOP & BOTTOM will fit into. The BACK CORNER PIECE can now be attached. The cabinet BACKS must be positioned to fit into the grooves in the BACK CORNER PIECE before being attached to the cabinet box.
7. Apply a bead of glue on the cabinet BACK where the HANGER CLEAT will be positioned. Slide the HANGER CLEAT into place. Using the scribe line on the CLEAT, pin the CLEAT into place. Do this for each HANGER CLEAT.

